

TECH-system

Type 239

For 2-parallel operation

Instructions for installation and use

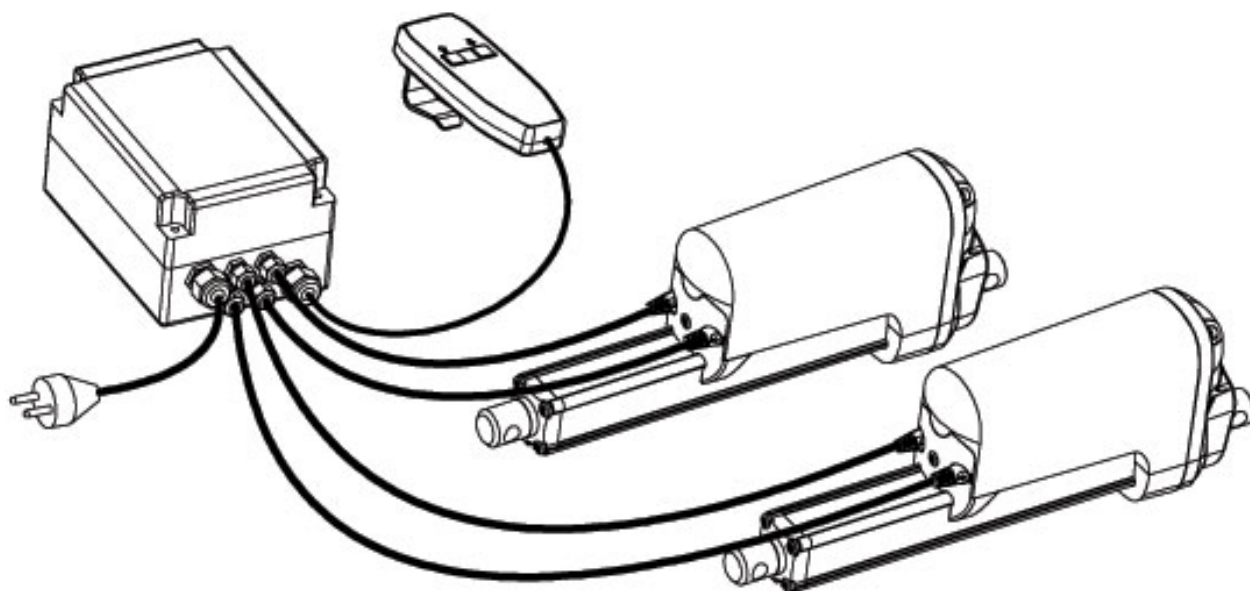

Preface

Dear User,

Thank you for choosing an actuator system from LINAK®. LINAK systems consist of hi-tech products that are based on many years of experience with the production and development of actuators, electronic control boxes, control units and chargers.

TECH-systems is composed of LINAK actuators and a motor control unit developed and produced by third party manufacturers. The function and operational reliability of TECH-systems have been tried and tested in a wide range of different situations. In addition, we continuously improve our products and systems so as to accommodate customer requirements.

This instruction manual describes how to install and maintain your TECH-system. We are sure that your TECH-system will provide you with many years of problem-free operation.

Before our products leave our factory, they always undergo comprehensive quality and function tests. In the unlikely event that you should experience any problems with your systems, please contact

LINAK Danmark A/S on +45 8680 3611.

LINAK provides a warranty on all its products and systems. However, this warranty is provided on condition that the product is used in accordance with the applicable specifications, that maintenance is performed correctly, and that any repairs are carried out at a workshop that is authorised to repair LINAK products.

Any changes to the installation and use of LINAK systems may affect their operation and durability. The products must never be opened by non-authorised persons.

LINAK Danmark A/S
Mønstedsvvej 9
DK-8600 Silkeborg

Important information

Important information about LINAK products is presented under the following headers:



Warning! Failure to comply with these instructions may result in accidents leading to serious personal injury.



NB! Failure to comply with these instructions may result in damage to or destruction of the product.

Warranty

The LINAK warranty covers manufacturing faults and defects in the products as calculated from the date of manufacture. Please contact LINAK Danmark A/S for additional information about the warranty period. The warranty is limited to the value of the LINAK product.

The LINAK warranty shall only apply if the system has been used correctly and has not been opened. The control box and control unit must not be exposed to violent use. Failure to comply with this requirement will void the warranty.

Safety instructions

Please read the following safety information carefully. It is essential that everyone who is to connect, install or use the system receive the necessary information and have access to this instruction manual. LINAK recommends that the actuators be used for push applications rather than pull applications.

It is essential that everyone who is to connect, assemble or operate the systems receive the necessary information and have access to this instruction manual.

Before installation, removal or troubleshooting:

- Stop the actuator.
- Disconnect the power supply and remove the mains plug from the socket.
- Free the actuator from any load that may be released during the work.

Before starting:

- Make sure that the system has been assembled as described in this instruction manual.
- Make sure that the current to the control box is correct before connecting the system to a power supply.
- System connection. The individual parts must be connected before the control box is connected to mains power.

During operation:

- If the control box emits unusual sounds or smells, disconnect the mains current and any external batteries.
- Make sure that the cables are not damaged.
- Disconnect the mains cable from mobile equipment before moving same.
- The products can be used both indoors and outdoors.

Classification:

The equipment is *not* suitable for use in the immediate vicinity of a flammable, anaesthetic mixture involving air, oxygen or laughing gas (nitrous oxide).

Environmental conditions:

Storage and transport	
Operating :	
Temperature Relative humidity Atmospheric pressure	5°C to 40°C 20% to 90% @ 30°C – not condensing 700 to 1060 hPa
Storage :	
Temperature Relative humidity Atmospheric pressure	-10°C to +50°C 20% to 90% @ 30°C – not condensing 700 to 1060 hPa
Transport :	
If the actuator is assembled in the application and is exposed to push or pull during transportation, the actuator can be damaged. Do not drop an actuator or otherwise damage the housing during disassembly or transportation. We do not recommend using an actuator which has been damaged.	



Warning!

The following applies if the actuator is used for traction in an application that involves a risk of personal injury:

It is the manufacturer of the application who is responsible for implementing appropriate safety measures designed to prevent personal injury in the event that the actuator fails.



Warning!

Please note that any application in which the actuator is involved must not feature any risk of personal injury, e.g. a risk of crushed fingers.



Warning!

The plastic components in the system cannot withstand cutting oil.

Table of contents.

Preface	2
Important information	3
Warranty	3
Safety instructions	3
Technical data	7
Description of the system	7
Motor control unit: (pos.1)	8
Power supply:	8
Actuator (pos.3)	9
Control device: (pos.2)	9
Dimensions	10
Rating plate and labelling	11
Declaration of Incorporation	12
Connection and installation	13
Fitting the motor control unit	13
Fitting a DC-DC converter	16
Connection of the motor control unit	17
Installing the actuators	18
Connection of LINAK actuators	19
Connection diagram for LINAK actuators	21
LA12/30 - Reed	22
LA28/32- Reed	22
LP2.2 – Reed	22
LA31 - Reed	23
LA35 – Hall	24
LA36 – Hall	24
BL1 – Hall	24
LA23 – Hall	25
LA23 – Dual Hall	25
LA36 – Dual Hall	25
Connection diagram for LINAK control devices	26
Parameter settings	27
Programming unit TR-EM-236	27
Parameters	28
<i>Explanation of parameters</i>	29
Start/operation	32
Initialisation	32
Appropriate use:	32
Inappropriate use:	32
Maintenance	33
Service operation	33
Reading monitoring values	33
<i>Explanation of monitoring values</i>	33
Operation	34
Initialisation	34
Service operation	34
Troubleshooting	35
Reading errors	35
Resetting errors	35
Disposal of LINAK products	36

Technical data

The TECH-system type 239 consists of: a motor control unit, actuators and an operating unit. Four versions of the motor control unit are available, with and without power supply. Ten different actuator types are available, as well as four different standard LINAK operating units.

Description of the system

The TECH-system type 239 has been developed for industrial purposes and is composed of two LINAK actuators. The system uses a specially designed motor control unit (TR-EM-239) to ensure that the actuators operate safely and in parallel.

If the motor control unit cannot maintain parallel operation between the actuators, the actuators are halted so as to prevent the risk of personal injury or mechanical overload. The motor control unit is fitted with a power switch and a temperature fuse with power gain.

The FORWARD and BACK commands can be received in continuous or impulse signal mode. In continuous activating mode, the actuators continue to operate for as long as the command signal is activated.

In impulse activating mode, only a single impulse is required to start and stop the movement of the actuators.

An externally connected display can be used to configure the motor control unit to operate various functions. For example, it is possible to adjust the acceleration/deceleration time, limit the stroke length, etc.

The TECH-System type 239 is compatible with a range of different LINAK actuators.

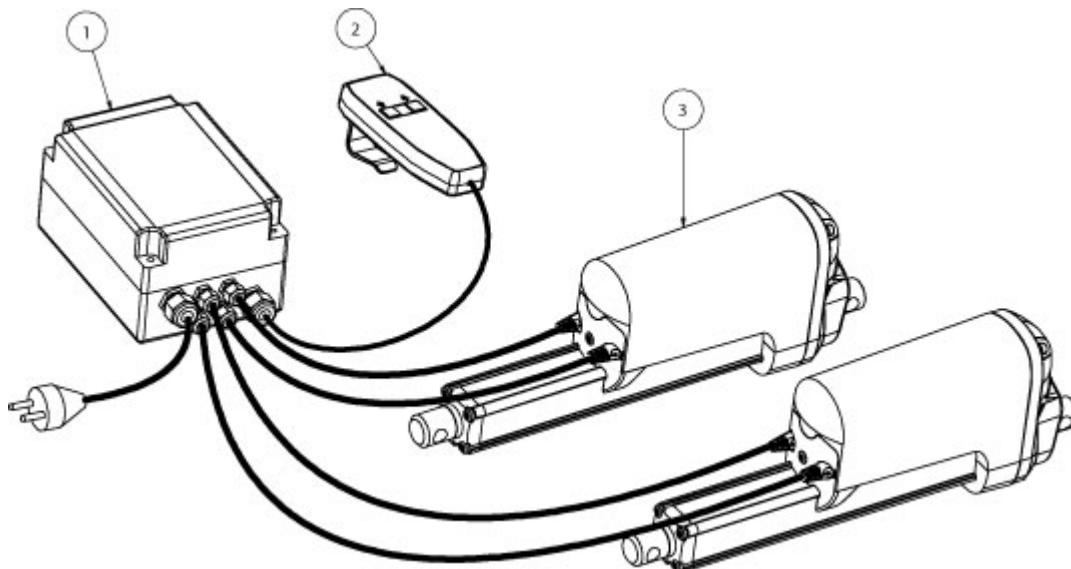

Motor control unit: (pos.1)

Type designation:	TR-EM-239
Actuator connection:	2 actuators in parallel operation
Actuator power limit:	2 x 10 A duty cycle 100% 2 x 20 A duty cycle 25 %
Actuator voltage:	24 V DC
Supply voltage to PCB:	10–35 V DC smoothed voltage
Current limit, setting:	1–20 A
PWM frequency:	2 kHz
Ramp times:	0–2 seconds
Pulse input frequency:	max. 1 kHz
Pulse inputs:	Positive/negative logic selection (10 kohm) High = 4–30 V Low = 0–1 V
Control inputs:	4–30 V = ON / 0–1 V = OFF
Input impedance:	10 kohm
Extra voltage output (AUX):	5 V – max. 10 mA
Operating temperature (Ta):	-20–60 °C

Four versions of the motor control unit TR-EM-239 are available:

- | | |
|-----------------------------------------------|----------------------------------|
| 1. Separate PCB: | Order no. TR-EM-239 |
| 2. PCB fitted in box: | Order no. TR-EM-239-H |
| 3. PCB mounted on DIN rail for panel mounting | Order no. TR-EM-239-R |
| 4. PCB fitted in box with power supply: | Order no. TR-EM-239-T-230 |

Power supply: (Only applies to TR-EM-239-T230) (pos.1)

Supply voltage:	230 V AC
Fuse:	T1, 6A3 20x5 tube
Max. Current:	10A
Continuous current:	3.5A
Transformer:	230/220 V – 150 Va

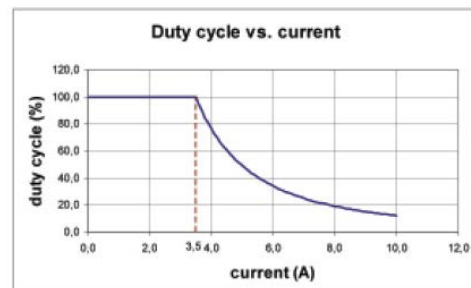
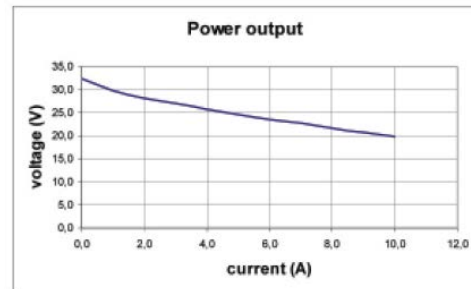

Power supply in plastic box

Order no. **TR-EM-000-T-230**

Actuator (pos.3)

The system is compatible with the following LINAK actuators:

- Actuator LA12 w/reed switch
- Actuator LA23 w/hall sensor
- Actuator LA23 w/dual hall sensor
- Actuator LA30 w/reed switch
- Actuator LA31 w/reed switch
- Actuator LA32 w/reed switch
- Actuator LA35 w/hall sensor
- Actuator LA36 w/hall sensor
- Actuator LA36 w/dual hall sensor
- Column LP2 w/reed switch
- Column BL1 w/hall sensor

(see the appropriate product data sheets for additional information)

Control device: (pos.2)

The system is compatible with the following LINAK control device

- | | |
|--------------------------------------|----------------------------------|
| • Desk-mounted operation, type DP1T: | Order no. DP1T00-000006 |
| • Desk-mounted operation, type TP1: | Order no. TP1010+00 |
| • Hand-held operation, type HB41T: | Order no. HB41T00-000009 |
| • Hand-held operation, type HB61: | Order no. HB61T00-000009 |
| • Rocker switch for building in: | Order no. TR-1939.3314-00 |

Other types of control devices can also be used.

Dimensions

Motor control unit TR-EM-239 as separate PCB

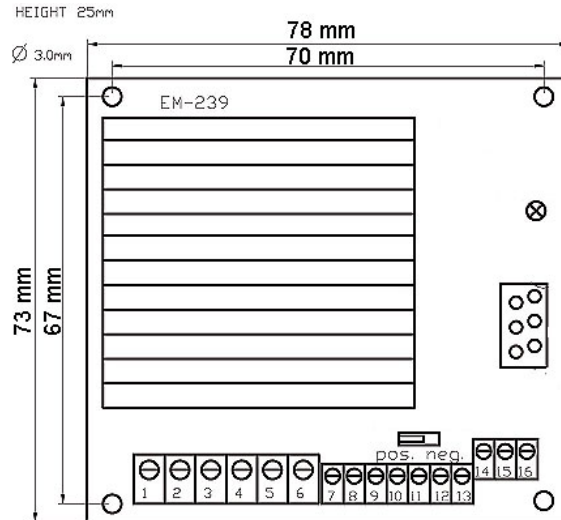

TR-EM-239 motor control unit fitted in a plastic box with built-in power supply

Weight 2.5 kg

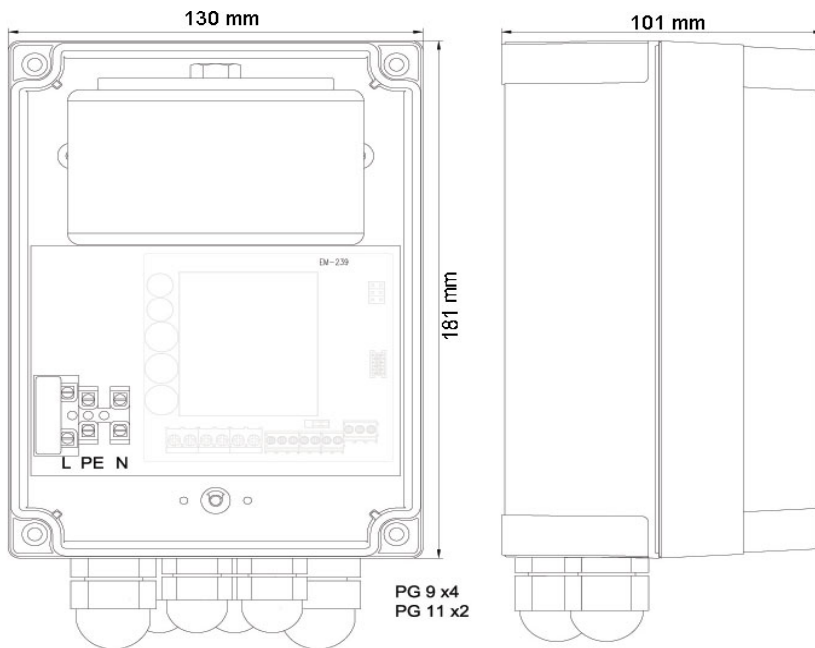

TR-EM-239 for mounting on DIN rail
for incorporating into an electrical panel

Weight: approx. 200 gram

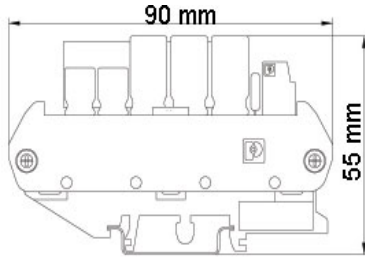

Fits to 35 mm DIN-rail or C-rail.

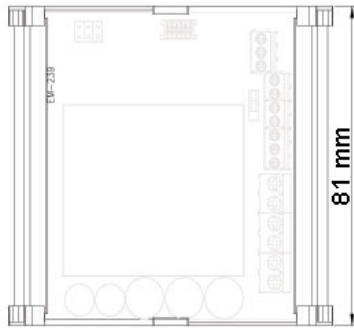

TR-EM-239 mounted in plastic housing without
power supply

Weight: approx. 300 gram

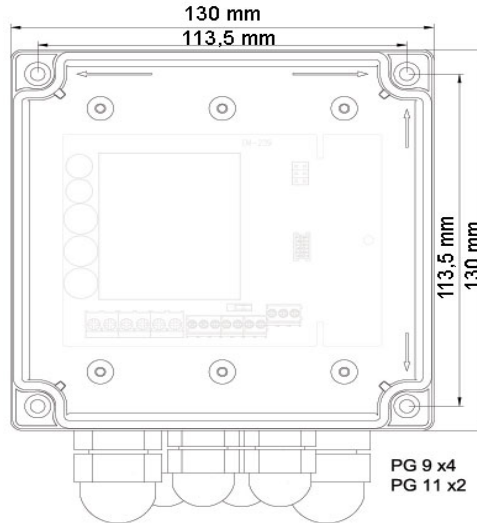
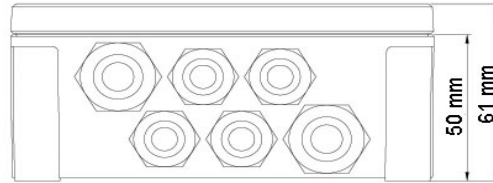

Rating plate and labelling

Rating plate on TR-EM-239 control unit:



Rating plate on actuator LA31 w/Reed

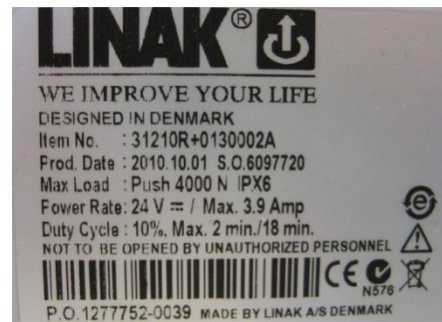

Declaration of incorporation of partly completed Machinery

Directive 2006/42/EC Annex II B

The signatory Manufacturer and authorised to compile the relevant technical documentation for partly completed Machinery and in response to a reasoned request by the national authorities transmit the relevant information:

LINAK Danmark A/S
Mønstedsvvej 9
DK-8600 Silkeborg

Declares that the partly completed machinery:

Description: Linear Actuator system for operating two Actuators in parallel
Name: **TECH-system**
Type: **239**

Consisting of:
LINAK Actuator type: **LA12 or LA23 or LP2 or LA28 or LA30 or LA31 or LA32 or LA35 or LA36 or BL1**

Motor controller unit: **TR-EM-239**

Operating unit: **HB40 or TP01 or DP1**

comply with the following parts of the essential health and safety requirements of the Directive 2006/42/EC Annex I:

1.2.1-safety and reliability of the control system; 1.2.2-control device; 1.2.3-starting; 1.2.4.1-stopping; 1.2.6-failure of the power system; 1.3.2-risk of brake-up during operation; 1.3.7-risks related moving parts; 1.3.8-choice of protection against risks arising moving parts.

comply with the requirements of the following EN Standards:

EN 13849-1:2008 SRP/CS Cat. B, PL = b og SRESW PL = b

comply with the requirements of the following EC Directives:

- Electromagnetic compability 2004/108/EF

The partly completed Machinery must not be put into service until the final machinery into which it is to be incorporated has been declared in conformity with the provisions of the Directive 2006/42/EC and other relevant Directives, where appropriate.

Date: Silkeborg

1/10-2012

Name and signature

Technical chief
Lars Omme

Connection and installation

Screw terminals are used to connect the TR-EM-239 motor control unit. A general description of the individual terminals is presented below. See the diagrams later in this manual for information about the correct connection of the different actuators.

Fitting the motor control unit

Four versions of the motor control unit TR-EM-239 are available:

- | | |
|-----------------------------------------------|----------------------------------|
| 5. Separate PCB: | Order no. TR-EM-239 |
| 6. PCB fitted in box: | Order no. TR-EM-239-H |
| 7. PCB mounted on DIN rail for panel mounting | Order no. TR-EM-239-R |
| 8. PCB fitted in box with power supply: | Order no. TR-EM-239-T-230 |

Separate PCB – TR-EM-239

The PCB is fitted using four 3 mm diameter screws and connected to an external power supply.

The height of the PCB is 25 mm.

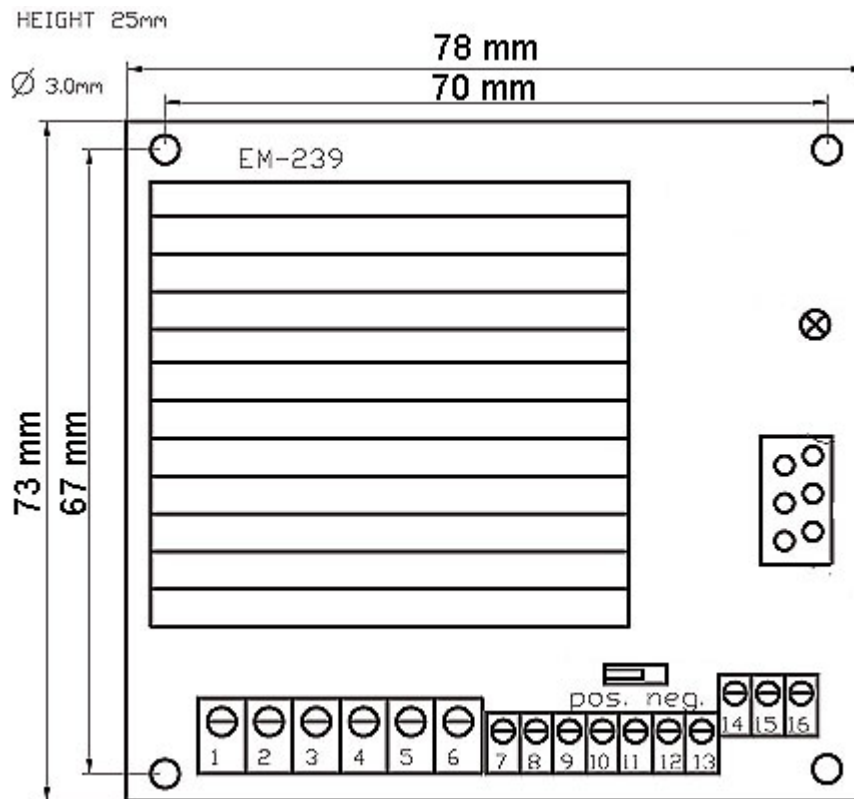

PCB fitted in box – **TR-EM-239-H**:

The box is fitted using four 3 mm diameter screws and connected to an external power supply. The box complies with encapsulation class IP66 and is thus well-suited to outdoor installation.

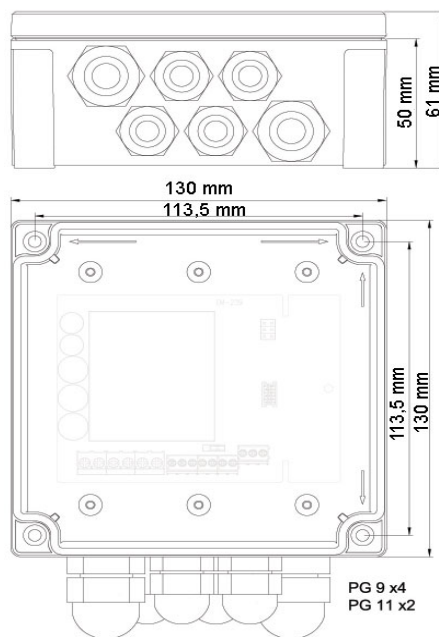

PCB fitted on DIN rail for panel installation – **TR-EM-239-R**

The PCB is mounted on a DIN rail and connected to an external power supply.

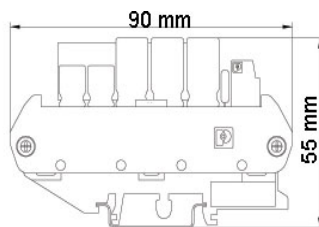

Fits to 35 mm DIN-rail or C-rail.

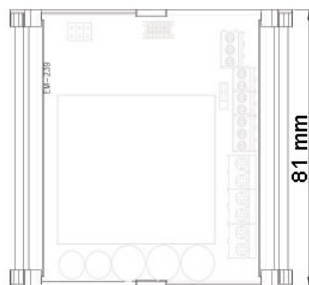

PCB fitted in box with internal power supply – TR-EM-239-T-230

The box is fitted using four screws and the power supply unit is connected to mains voltage as shown below.

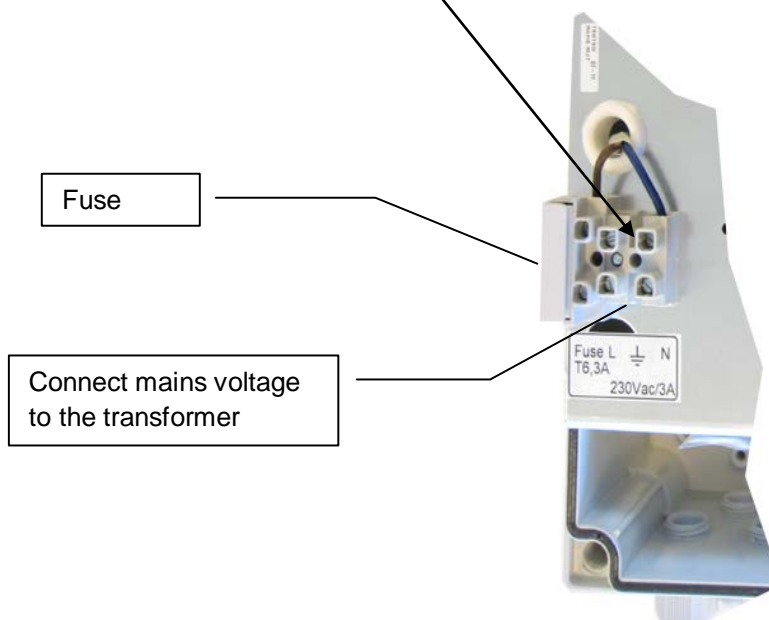
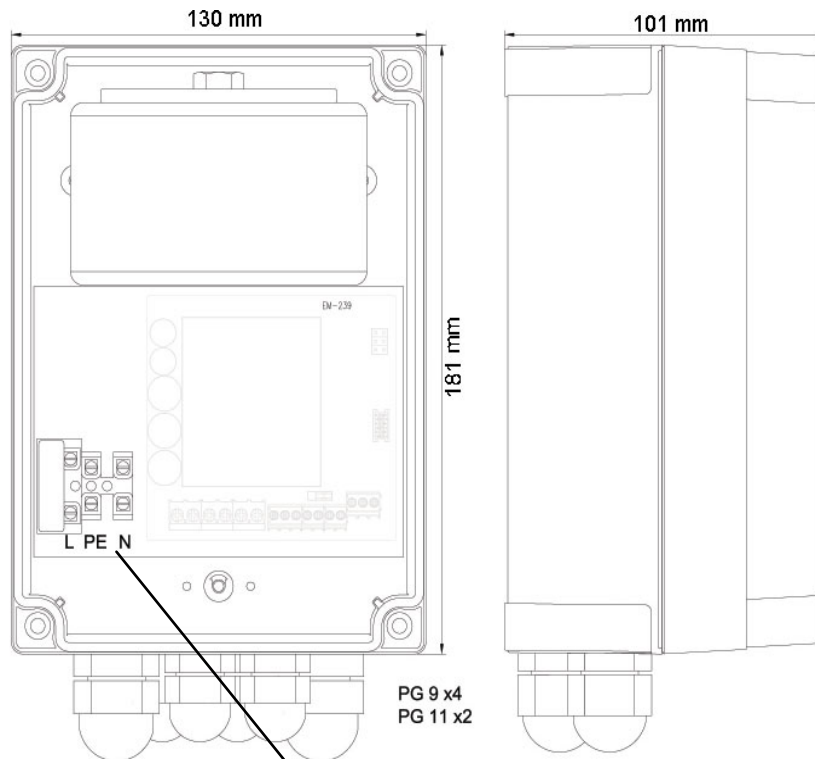

Fitting a DC-DC converter

When using a LA35 actuator or BL1 Lift column, the DC voltage to the Hall sensor in the actuator must be regulated to a constant 12 V. To do this, fit the DC-DC converter, **EM-311-DK**

The converter is easily fitted in the TR-EM-239-T-230 box beside the transformer. The converter must be ordered separately.

DC-DC converter

Order no.: EM-311-DK



Installing the DC-DC converter:



To connect the converter, see diagram on page 23.

Connection of the motor control unit

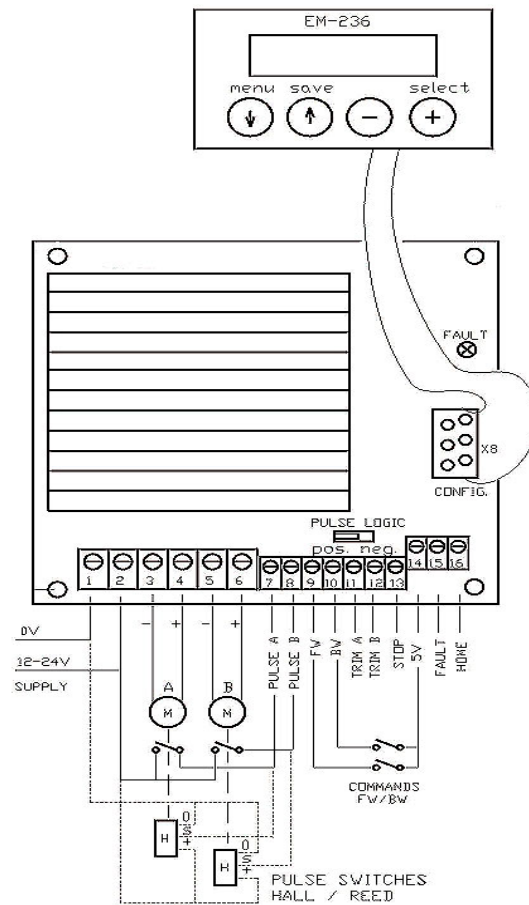

- Terminal 1: Supply voltage (- gnd)
- Terminal 2: Supply voltage (+ 10–35 V DC) smoothed voltage
- Terminal 3: Voltage to motor on actuator 1 (-24 V DC)
- Terminal 4: Voltage to motor on actuator 1 (+24 V DC)
- Terminal 5: Voltage to motor on actuator 2 (-24 V DC)
- Terminal 6: Voltage to motor on actuator 2 (+24 V DC)
- Terminal 7: Reed/hall signal from actuator 1
- Terminal 8: Reed/hall signal from actuator 2
- Terminal 9: If terminals 9 + 14 are connected, the actuators run FORWARDS
- Terminal 10: If terminals 10 + 14 are connected, the actuators run BACKWARDS
- Terminal 11: Hall -A signal from actuator 2 /OR Service operation for actuator 1. If terminals 11 + 14 are connected, ONLY actuator 1 will respond when operation is activated.
- Terminal 12: Hall -B signal from actuator 2 /OR Service operation for actuator 2. If terminals 12 + 14 are connected, ONLY actuator 2 will respond when operation is activated.
- Terminal 13: STOP. If terminals 13 + 14 are connected, all operation will stop (end stop switch)
- Terminal 14: 5 V output.
- Terminal 15: Error output. External relay, if any, connected – (gnd)
- Terminal 16: HOME. Actuators forced to return to starting position and system initialised.

Installing the actuators

When installing actuators, it is important to make sure that the actuators can move freely along their full stroke length, without being limited by the mechanical construction. It is also important to ensure that the application is not subjected to uneven twisting and traction, nor to unevenly distributed load.



NB! The actuator must only be secured using the piston end and rear fastening plate – never the outer tube of the spindle or the motor housing.

For additional information, please refer to the data sheet for the actuator in question.

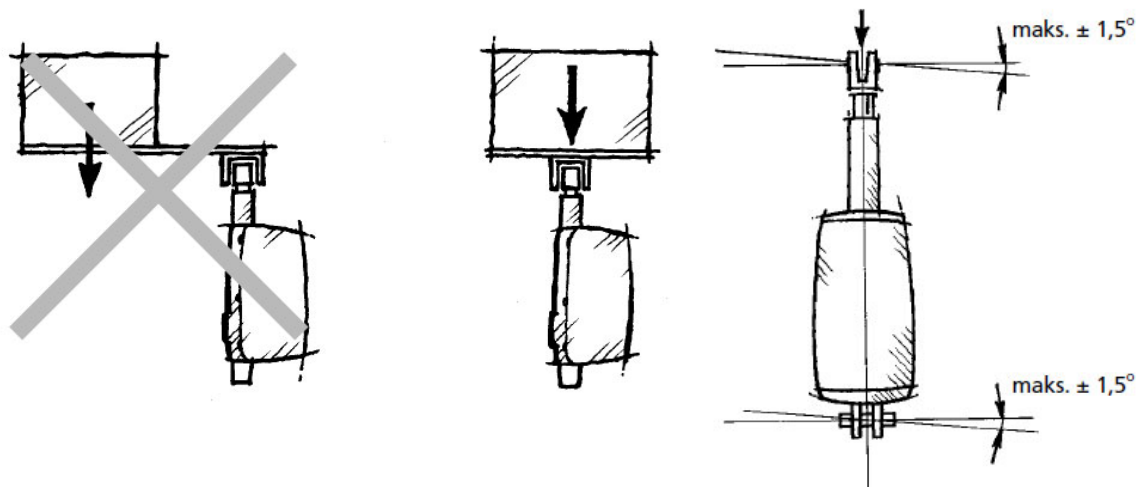

Connection of LINAK actuators

The majority of LINAK actuators are supplied as standard with a pre-fitted cable, and the actuators are also fitted with different types of plugs depending on which control box has been selected for the control operations. For operation with TR-EM-239, the actuators are typically supplied without plugs. The cable may vary with regard to the number of conductors and the respective colours depending on the type of feedback the actuator is fitted with. The pictures below show the different types of cables that are fitted to the compatible actuators.

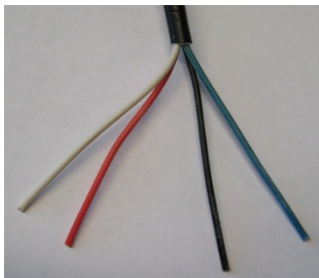
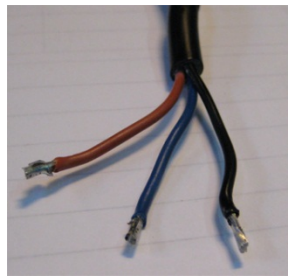
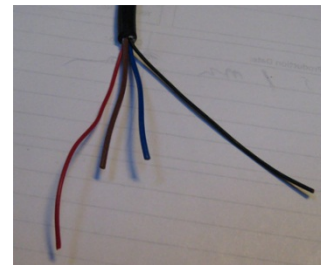
LA12/30 with reed**LA28/32/LP2.2 with reed****LA31 with reed**

The new generation of actuators is fitted with minifit plugs in the motor housing, and are thus supplied without fitted cables. In contrast to the cable types mentioned above, the supply and signal conductors have now been separated and are thus in individual cables.

LA35

LA36

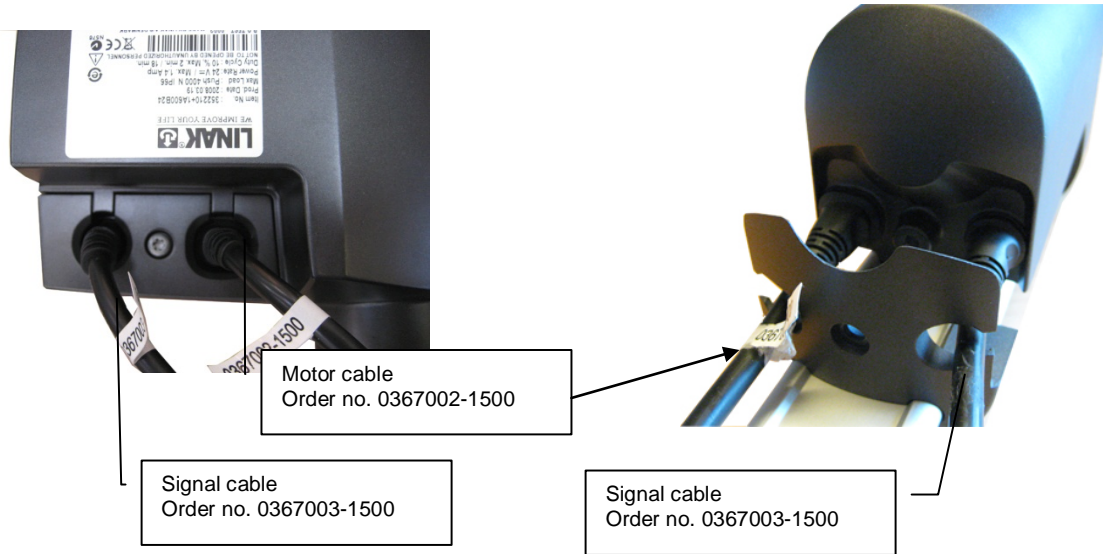

LA23 / BL1

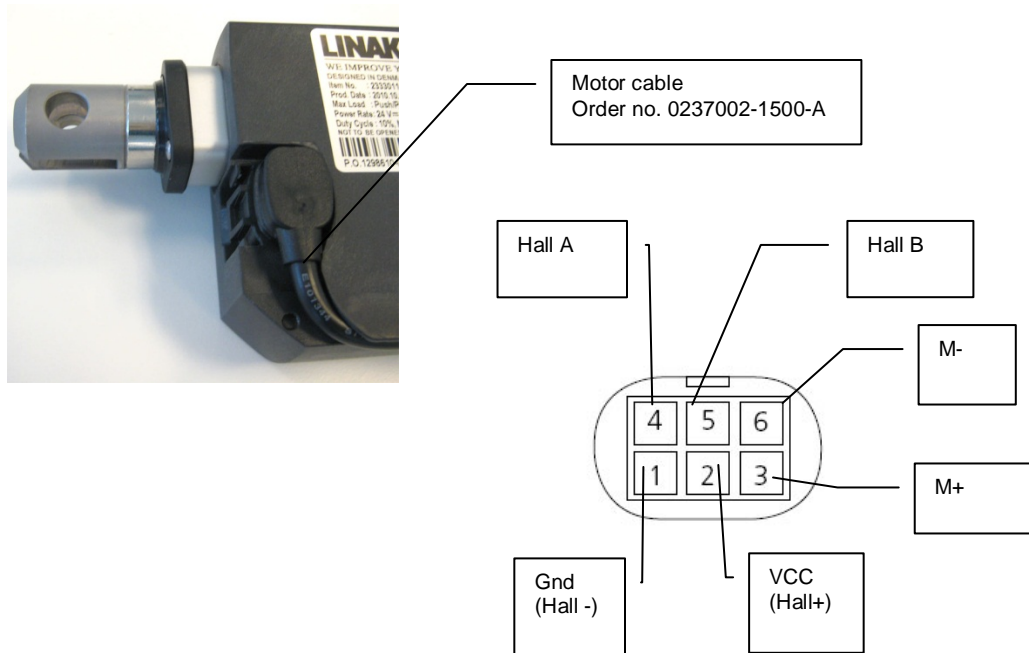

Connection diagram for LINAK actuators

The following pages present diagrams for the various types of actuators.

- Actuator LA12 w/reed switch
- Actuator LA23 w/hall sensor
- Actuator LA30 w/reed switch
- Actuator LA31 w/reed switch
- Actuator LA32 w/reed switch
- Actuator LA35 w/hall sensor
- Actuator LA36 w/hall sensor
- Actuator LA23 w/Dual hall sensor
- Actuator LA36 w/Dual hall sensor
- Column LP2 w/reed switch
- Column BL1 w/hall sensor

LA12/30 - Reed

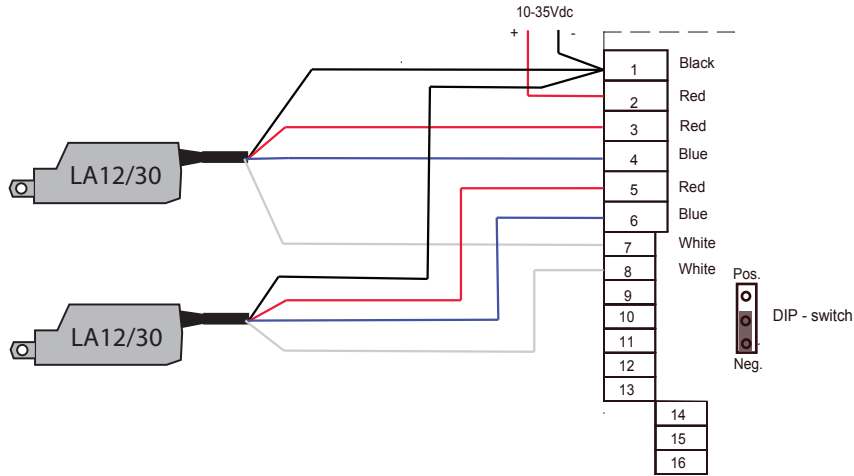

Parameter Values

- 1 = 100
- 2 = 60
- 3 = 5
- 4 = 0
- 5 = 20
- 6 = 10
- 7 = 5
- 8 = 0
- 9 = 1
- 10 = 1
- 11 = 0
- 12 = 0
- 13 = 0
- 14 = 0

LA28/32 - Reed

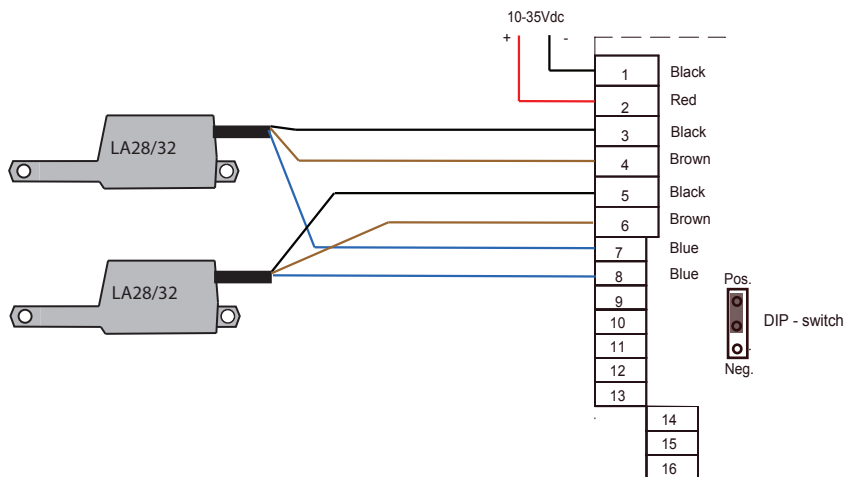

Parameter Values

- 1 = 100
- 2 = 60
- 3 = 5
- 4 = 0
- 5 = 50
- 6 = 10
- 7 = 5
- 8 = 0
- 9 = 1
- 10 = 1
- 11 = 0
- 12 = 0
- 13 = 0
- 14 = 0

LP2 - Reed

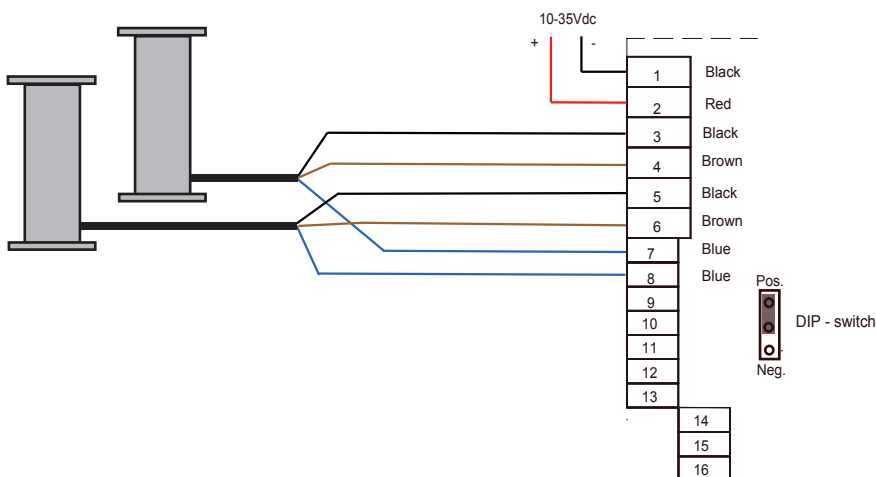

Parameter Values

- 1 = 100
- 2 = 60
- 3 = 5
- 4 = 0
- 5 = 50
- 6 = 10
- 7 = 5
- 8 = 0
- 9 = 1
- 10 = 1
- 11 = 0
- 12 = 0
- 13 = 0
- 14 = 0

LA 31 - Reed

Parameter Values

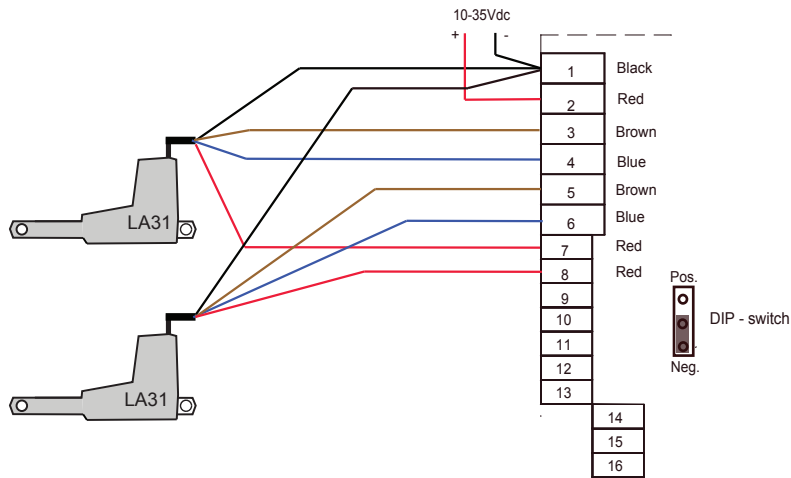

- 1 = 100
- 2 = 60
- 3 = 5
- 4 = 0
- 5 = 50
- 6 = 10
- 7 = 5
- 8 = 0
- 9 = 1
- 10 = 1
- 11 = 0
- 12 = 0
- 13 = 0
- 14 = 0

LA 35 - Hall

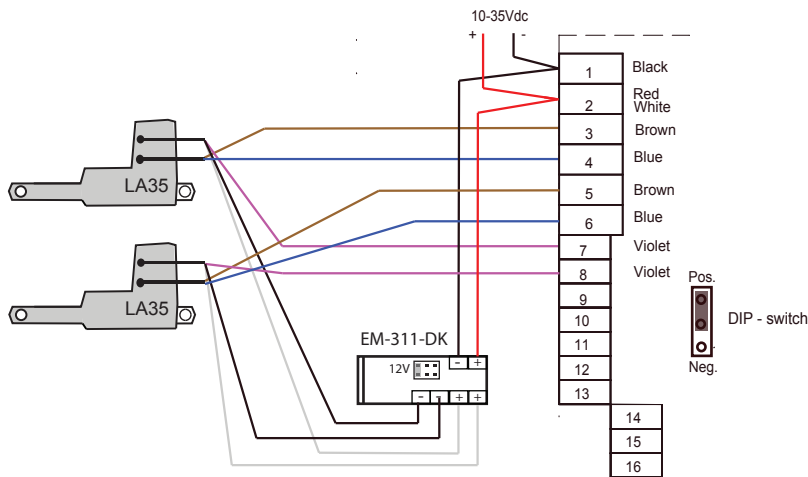

Parameter Values

- 1 = 100
- 2 = 60
- 3 = 0
- 4 = 0
- 5 = 50
- 6 = 10
- 7 = 5
- 8 = 0
- 9 = 1
- 10 = 1
- 11 = 0
- 12 = 0
- 13 = 0
- 14 = 0

LA 36 - Hall

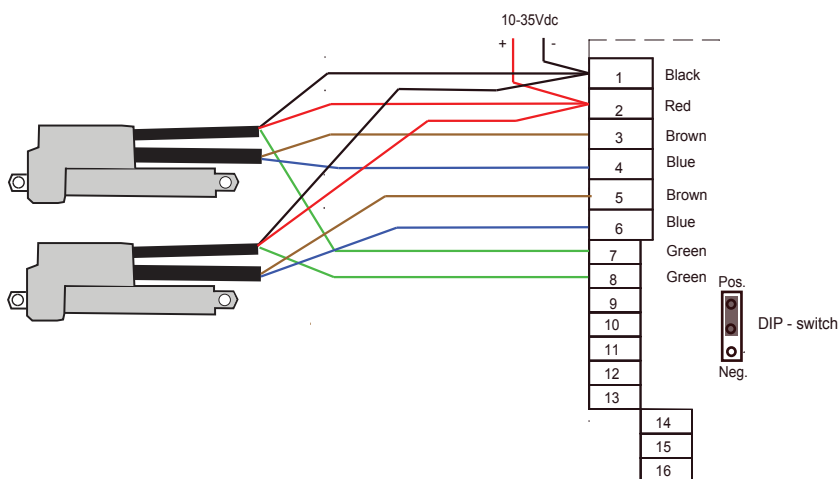

Parameter Values

- 1 = 100
- 2 = 60
- 3 = 5
- 4 = 0
- 5 = 100
- 6 = 10
- 7 = 5
- 8 = 0
- 9 = 1
- 10 = 1
- 11 = 0
- 12 = 0
- 13 = 0
- 14 = 0

BL1- Hall

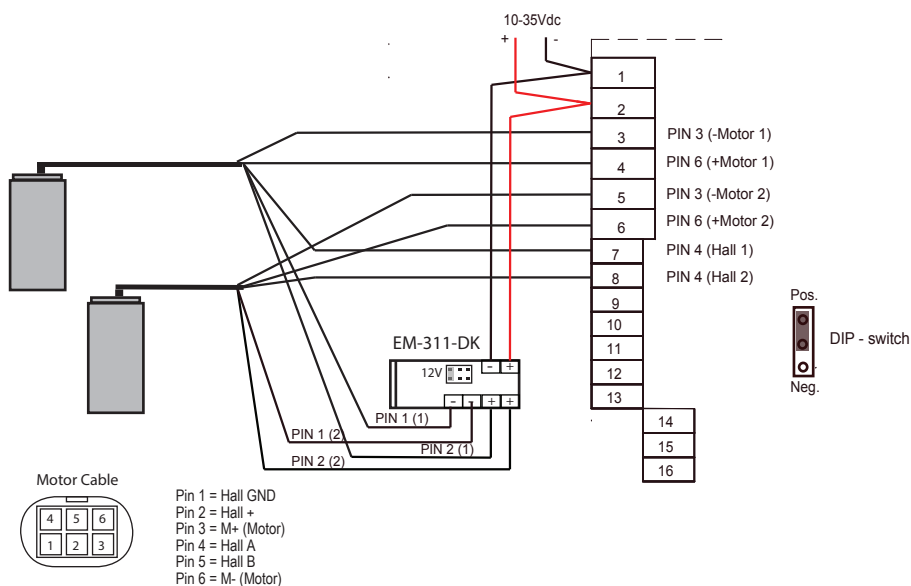

Parameter Values

- 1 = 100
- 2 = 60
- 3 = 0
- 4 = 0
- 5 = 50
- 6 = 10
- 7 = 5
- 8 = 0
- 9 = 1
- 10 = 1
- 11 = 0
- 12 = 0
- 13 = 0
- 14 = 0

LA 23 - Hall

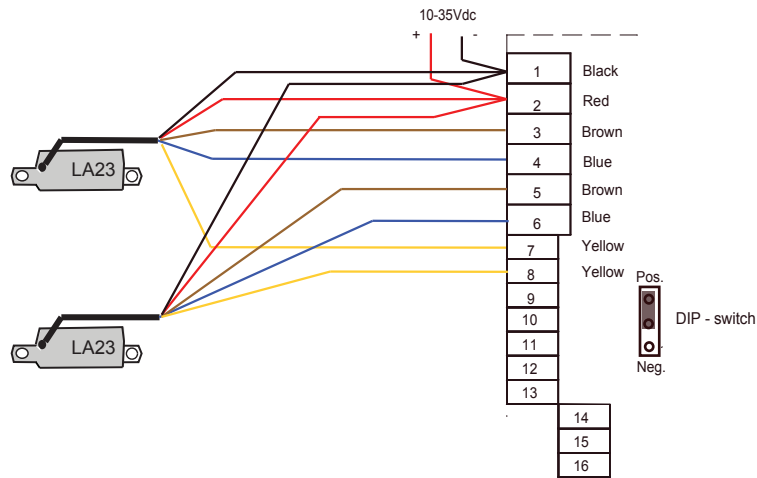

Parameter Values

- 1 = 100
- 2 = 60
- 3 = 5
- 4 = 0
- 5 = 20
- 6 = 10
- 7 = 5
- 8 = 0
- 9 = 1
- 10 = 1
- 11 = 0
- 12 = 0
- 13 = 0
- 14 = 0

LA 23 - Dual Hall

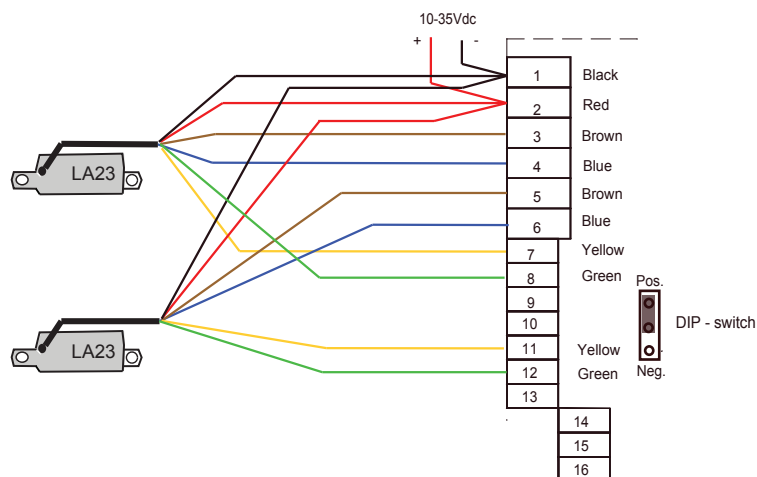

Parameter Values

- 1 = 100
- 2 = 60
- 3 = 5
- 4 = 0
- 5 = 20
- 6 = 10
- 7 = 5
- 8 = 0
- 9 = 1
- 10 = 1
- 11 = 0
- 12 = 0
- 13 = 1
- 14 = 0

LA 36 - Dual Hall

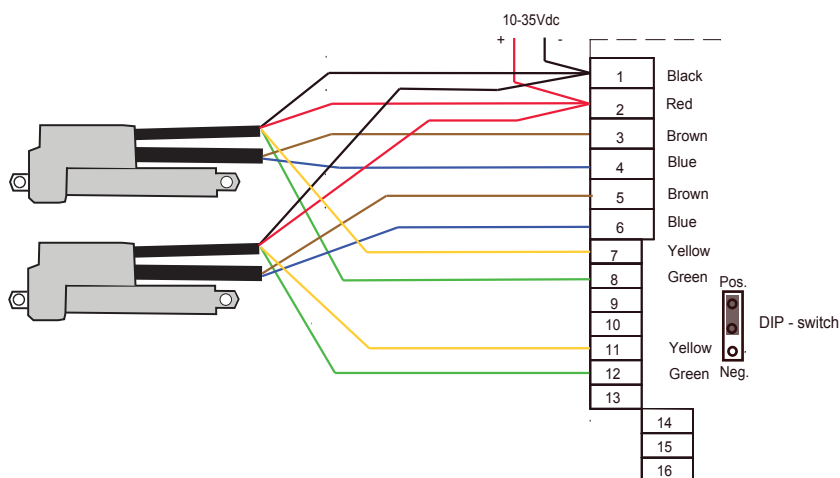

Parameter Values

- 1 = 100
- 2 = 60
- 3 = 5
- 4 = 0
- 5 = 100
- 6 = 10
- 7 = 5
- 8 = 0
- 9 = 1
- 10 = 1
- 11 = 0
- 12 = 0
- 13 = 1
- 14 = 0

Connection diagram for LINAK control devices

HB41T + HB61T + TP1 + DP1O

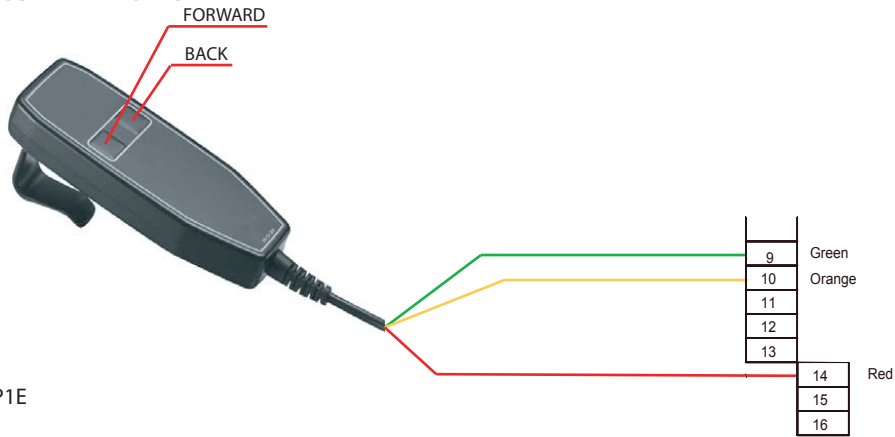

DP1K + TP1E

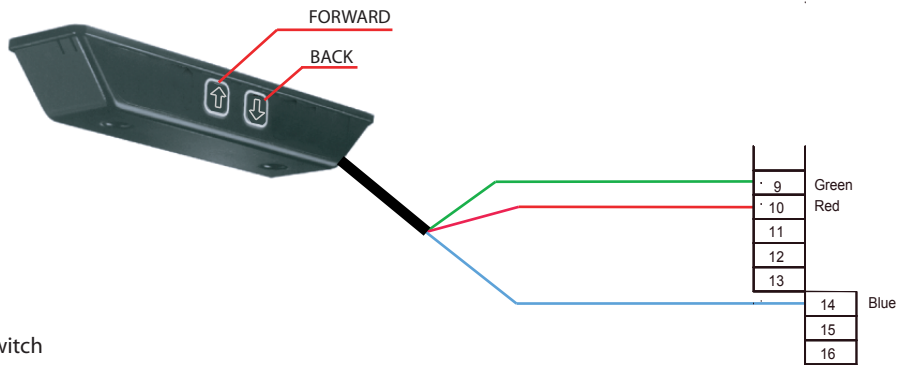

Rocker switch

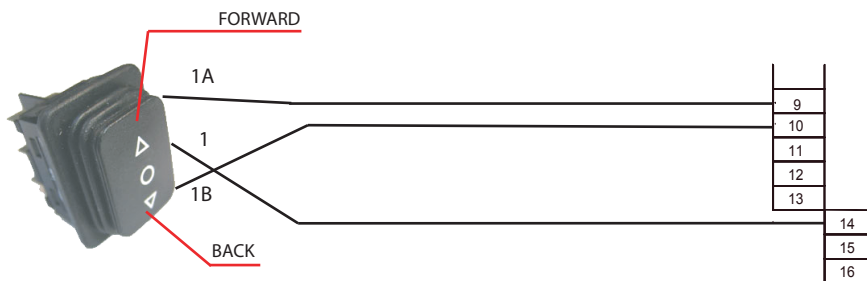

Buttons for Service operation

Parameter 13 = 0

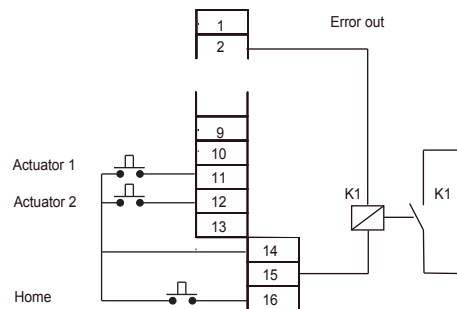

Parameter settings

As standard, the TR-EM-239 motor control unit has 11 parameters that can be set to match the individual application. The TR-EM-239 with advanced software version 1.4 has 14 parameters. For it to be possible to change these parameters, programming unit TR-EM-236 must be connected to the motor control unit.

NB! The control unit must be connected to a power supply while programming.

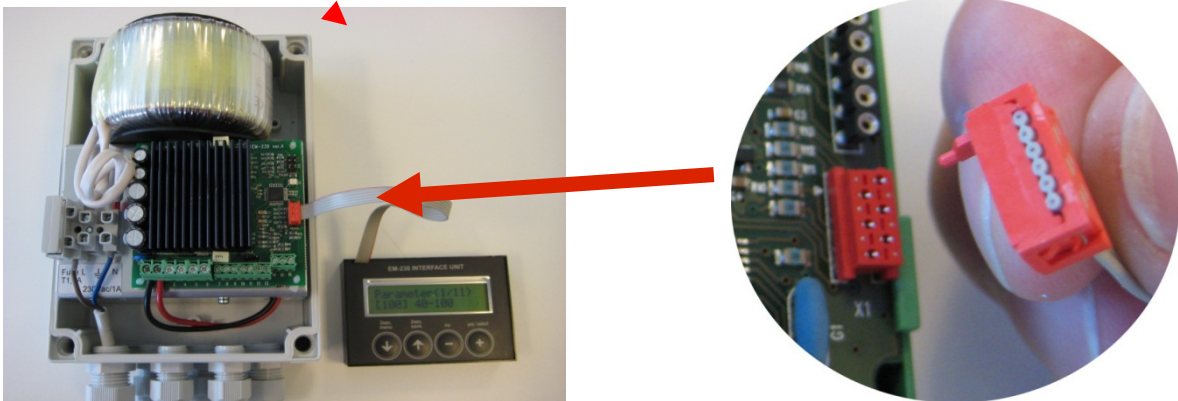

Programming unit TR-EM-236

Press ARROW DOWN for 2 seconds to call up the main menu of the programming unit. In the main menu, use ARROW UP or ARROW DOWN to select the menu item required. To open the menu in question, click the + (plus) button.

To alter the parameter values, select the "Load & Edit" menu item

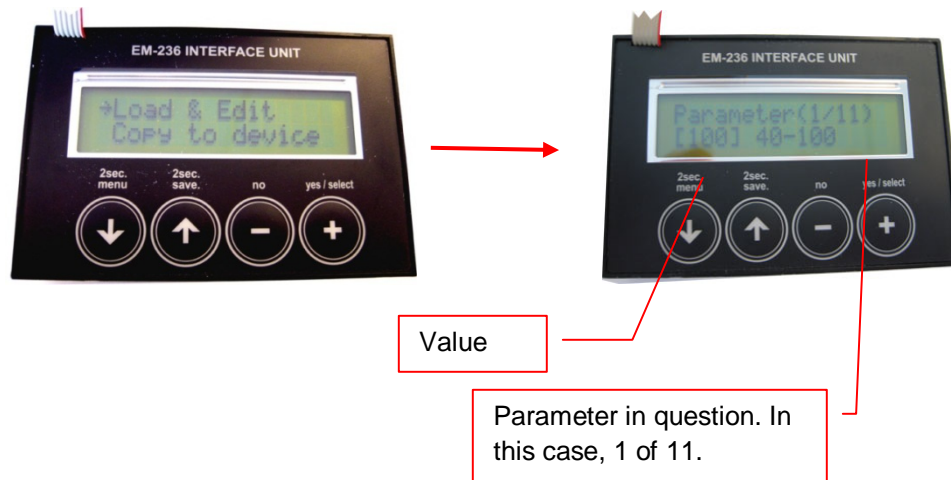

Use the arrow keys to select the parameter you wish to alter. The parameter selected is shown in the display as <1 / 11>, which means parameter 1 of 11. The value is presented in square brackets [] and can be changed by pressing the plus or minus buttons.

Once you have made the changes you require, save the new configuration by pressing ARROW UP for at least 2 seconds.



Parameters

The following parameters can be adjusted as required or desired:

- | | |
|--------------------------|-----------------------------------------------------------------------------------------------------------------------------|
| 1. Speed: | Set the operating speed of the actuators |
| 2. Initialisation speed: | Set reduced speed during initialisation operation |
| 3. Start ramp: | Set ramp time, Start |
| 4. Stop ramp: | Set ramp time, Stop |
| 5. Power limit: | Set the max. power limit. |
| 6. Deviation in pulses: | Set the max. permissible deviation in pulses |
| 7. Regulation behaviour: | Set hard or soft regulation behaviour |
| 8. Error indication: | Set activated or deactivated error indication |
| 9. Start conditions: | Set the direction the actuators are to run after ERRORS |
| 10. Operating mode: | Define whether pulse activating or continuous activating on push is required |
| 11. Power-on: | Set whether the control unit is to perform an automatic initialisation every time voltage is connected to the control unit. |
| 12. Auto-initialisation: | Set the starting point for automatic initialisation |
| 13. Dual pulse mode: | Set utilisation of Dual hall pulse feedback. |
| 14. End stop OUT: | Set maximum stroke length, OUT. |

Explanation of parameters

The following section presents a more detailed explanation of the individual parameters. Set the parameters by entering a number in the display.

NB! LINAK's recommended parameters are presented in { } after each description below.

1

Speed:

This parameter makes it possible to set the operating speed of the actuators. The speed is stated in %. Max. speed = 100%.
The following options are available:

40 – 100 {100}

2

HOME speed:

This parameter makes it possible to set the reduced speed with which the actuators are to return to their starting position. The speed is stated in %. Max. speed = 60%.

The following options are available:

20 – 60 {60}

3

Start ramp:

This parameter makes it possible to set the start ramp to a soft start. The ramp time is measured in seconds from 0–2.0 sec.

The following options are available:

0 to 20 {5}

4

Stop ramp:

This parameter makes it possible to set the stop ramp to a soft start. The ramp time is measured in seconds from 0–2.0 sec.

The following options are available:

0 to 20 {0}

5

Current limit:

This parameter is used to state the max. permitted power consumption for each actuator connected. The power limit is measured in Amp. From 1–20 A.

The following options are available:

10 to 200 {50} (should be checked in every case)

6

Deviation in pulses:

This parameter is used to state the permissible deviation in feedback from the actuators before the control unit synchronises. The deviation is stated between 3–50 pulses.

The following options are available:

3 to 50 {10}

7

Regulation behaviour:

This parameter is used to define the behaviour regarding how quickly and intensely the control system adjusts the synchronisation between actuator 1 and 2. The parameter defines whether the adjustment is to be soft or aggressive. (1= soft and 5=aggressive)

The following options are available:

1 to 5 {5}

8

Error indication:

This parameter is used to define whether the control unit is to provide an error message when the control unit cuts out on account of overcurrent.

The following options are available:

0 = deactivated

1 = activated

{0}

9

conditions:

This parameter is used to define whether the control unit is to restart the actuators in both directions, or only in the opposite direction after having cut out on account of overcurrent or a stop command.

The following options are available:

0 = both directions

1 = back only in the event of overcurrent

2 = back only in the event of a STOP command (end stop)

3 = back irrespective of cause

{1}

10

Operating mode:

This parameter is used to define how the control unit is to react when a push button is activated. You can choose between continuous and impulse mode.

- in **continuous activating mode** the actuators will operate as long as a button is pushed and stops as soon as the button is released.

- in **impulse activating mode** the actuators are started by pushing a button once, and the direction is changed by pressing the button for the opposite direction. The actuators only stop if they receive a stop command or on end stop.

- in **impulse-2 activating mode** the actuators are started by pressing the FORWARD/BACK button (impulse) once. The following command stops the actuators, and the next command (FORWARD/BACK) starts the actuators again.

In all modes, the actuators are stopped by pulse deviations, the power limit and the STOP command.

The following options are available:

1 = continuous mode

2 = impulse mode

3 = impulse-2 mode {1}

11

Power ON:

This parameter makes it possible to set the control unit to run an automatic HOME procedure every time voltage is reapplied to the control unit.

The following options are available:

0 = deactivated

1 = activated

{0}

12

Auto initialisation:

This parameter sets the starting point for automatic initialisation. The value is measured in the number of pulses from the innermost position of the actuator.

The value "0" indicates that the function is deactivated

The following options are available:

0–255

{0}

13

Dual-hall pulse mode:

This parameter is used when Dual-hall pulse feedback is applied. (See also diagram on page 23)

The following options are available:

0 = deactivated

1 = activated

{0}

14

End stop OUT:

This parameter is used to limit the stroke length. Enter the number of pulses that the actuator needs to move to its outermost position. The value "0" indicates that the function is deactivated

The following options are available:

0–32000

{0}

Start/operation

Before starting to use the system, it is important that all parameters have been set correctly according to the diagram. The first time the system is used, it must be initialised to ensure that the actuators are operating identically. The system is then ready for operation and the TR-EM-236 portable serial interface handset can be disconnected.

Initialisation

The initialisation routine can be started by pressing *(ARROW UP and ARROW DOWN) simultaneously for 3 seconds or by sending an incoming signal to "Home input, terminal 16". If parameter no. 11 "Power on" is set to "1", the initialisation routine will be started every time the unit is powered up. The initialisation routine can be interrupted with a new FORWARD or BACKWARD command or a STOP signal. When the initialisation routine starts, both actuators begin to move in the same direction and will continue to operate until the power limit stops the motor or the pulses cease. During the routine, the error LED flashes slowly. When it stops flashing, both motors have stopped and the unit has reset the pulse counters. The unit is now initialised and ready to use.

*(Applies only if LINAK control units are used)



IMPORTANT! The keys must be depressed throughout the initialisation process or the control unit will stop communicating with the actuators and the procedure will have to be restarted.

Appropriate use:

- The system is only intended/designed for use as a component part in machinery or equipment used in an industrial environment.
- After fitting, test the system to check that it functions correctly.
- The application must be allowed free movement along the full stroke length of the actuator.
- Bolts attached to the actuator's piston rod eye and back fixture must be secure.
- Ensure that the system is connected to the correct voltage.

Inappropriate use:

- Duty cycle must not exceed 10%: max. 2 min. operation followed by an 18-minute pause
- The actuator must not bear a load in excess of the max. load stated on the data plate.
- The actuator must not bear a transverse load.
- The actuator must not be subjected to knocks and violent jolts.
- Unevenly distributed loads will exert oblique stress on the actuators.
- The system must not be connected to a different voltage than the voltage stated on the data plate.
- The control box and power supply must not be covered.
- The equipment is not suitable for use in the vicinity of flammable, anaesthetic mixtures of air, oxygen or nitrous oxide (laughing gas).
- The system is not suitable for applications which can be described as:
 - medical devices
 - equipment for use in the offshore industry (ATEX)
 - aircraft
 - nuclear power plant
- The system must not be used until it is incorporated into the end product.

Maintenance

- Clean the surface of the systems at appropriate intervals to remove dust and dirt, and check for signs of damage and breakage.
- Check all connections, cables, housing and connectors, and check that the system functions correctly.
- With the exception of motor control units with PCB or those prepared for mounting in an electrical panel, the control boxes are sealed and maintenance-free.
- Check all connections, cables, housing and contacts.
- For actuators with sealing class IPX6 rating and better: If cleaned using water, these units should only be washed when the piston rod (spindle) is fully extended.

Service operation

In some situations, it may be necessary to operate the actuators individually. This function can be established by connecting two push-buttons to terminal 11 (actuator 1) and terminal 12 (actuator 2). (See the connection diagram for operating units on page 26).

Using the control unit – ARROW UP or ARROW DOWN – while simultaneously depressing the push-button for the actuator in question, only the actuator in question will operate.



WARNING! Make sure that the application will not be twisted or deformed if one of the actuators is not operating.

Reading monitoring values

By using programming unit TR-EM-236, it is possible to read the current values for the system. Four values can be displayed.



In the main menu, use ARROW DOWN to select the “Monitor Values” menu.

Explanation of monitoring values

- | | |
|------------------------------------|-----------------------------------------------------------------------------|
| 1. Current, actuator 1 | 10-200 = 1-20A |
| 2. Current, actuator 2 | 10-200 = 1-20A |
| 3. Number of pulses | Displays the current number of pulses measured on actuator 1 |
| 4. Deviation in pulses actuator 2. | Displays the current deviation in pulses between actuator 1 and actuator 2. |
| 5. Position 1 | Displays the current position, measured in pulses, for actuator 1 |
| 6. Position 2 | Displays the current position, measured in pulses, for actuator 2 |

Operation

Before starting to use the system, it is important that all parameters have been set correctly according to the diagram. The first time the system is used, it must be initialised to ensure that the actuators are operating identically. The system is then ready for operation and the TR-EM-236 programming unit can be disconnected.

Initialisation

The initialisation routine can be started by pressing *(ARROW UP and ARROW DOWN) simultaneously for 3 seconds, or by sending an incoming signal to "Home input terminal, 16". If parameter no. 11 – Power on - is set to "1", the initialisation routine will be started every time current is connected to the unit. The initialisation routine can be interrupted with a new FORWARD or BACK command or a STOP signal. When the initialisation routine starts, both actuators begin to move in the same direction and will continue to operate until the power limit stops the motor or the pulses cease. During the routine, the error LED flashes slowly. When it stops flashing, and both motors have stopped, the unit has reset the pulse counters. The unit is now initialised and ready to use.

*(Only applies if LINAK operating units are used)



IMPORTANT! The buttons must be kept pressed throughout the initialisation process or the control unit will lose connection with the actuators and the procedure will have to be restarted.

Service operation

In some situations, it may be necessary to operate the actuators individually. This function can be established by fitting two push-buttons connected to terminal 11 (actuator 1) and terminal 12 (actuator 2). (See the connection diagram for control device page 24)

By using the push-button – ARROW UP or ARROW DOWN – while simultaneously pressing the push-button for the actuator in question, only the actuator in question will operate.



WARNING! Make sure that the application will not be twisted or deformed if one of the actuators is not operating.

Troubleshooting

If an error occurs, the actuators will stop operating and the error condition will be indicated by a red LED on the PCB. The LEDs are visible when the cover of the control unit is removed.

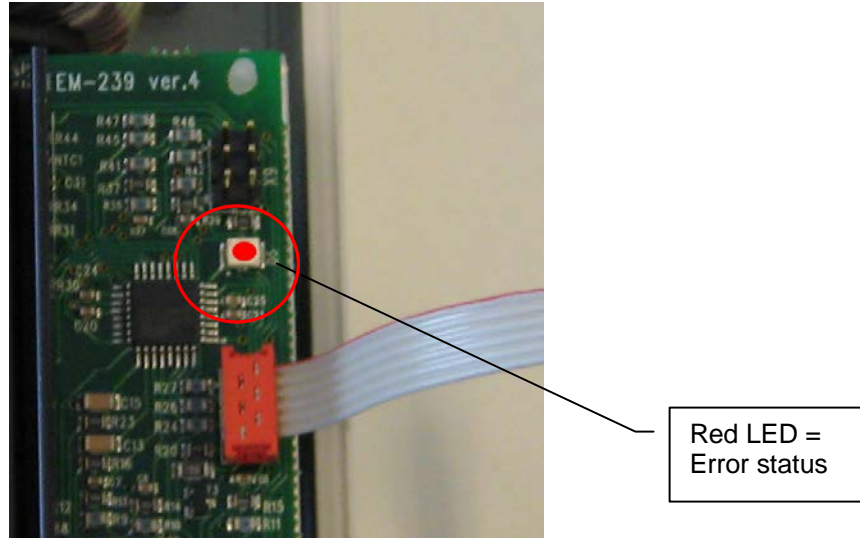

Reading errors

In the event of an error, the red LED will flash. The flashes have the following meaning:

Number of flashes	Meaning	Check this
2 flashes	Disconnected on account of over current	<ul style="list-style-type: none"> - Too heavy load. Release some loads from the Actuators - Check that the value parameter 5 is correct
3 flashes	No pulses	<ul style="list-style-type: none"> - Check the cabling and connections at Terminal 7 and 8 - Replace Actuator
4 flashes	Deviation in pulses	<ul style="list-style-type: none"> - Initialise the system
5 flashes	Overheating	<ul style="list-style-type: none"> - Stop system and wait until it is cooled down

Resetting errors

All errors are reset when the actuators are restarted.

Disposal of LINAK products

To dispose of LINAK products, start by sorting them into different categories for recycling or incineration. We recommend that you dismantle your product as fully as possible for disposal, and that you reuse the parts. Sorting categories may include:

metal, plastic, cables, combustible material and material for recycling. It is possible to subdivide within some of these categories. For example, "metal" can be subdivided into steel and aluminium, while "plastic" can be divided into ABS and PP. As an example of sorting, the table below illustrates the various categories under which the LINAK components are to be sorted.

Product	Component	Recycling group
Actuator:	Spindle and motor Plastic housing Cable	Metal scrap Plastic recycling or combustion Cable scrap or combustion
Control box:	PC-board Plastic housing Cable Transformer Batteries	Electronics scrap Plastic recycling or combustion Cable scrap or combustion Metal scrap Recoverable resources
Control:	Plastic housing Cable PC-board	Plastic recycling or combustion Cable scrap or combustion Electronics scrap